



DATA SHEET NO. 7100-502

MEL-ROL® Rolled, Self-Adhering Waterproofing Membrane

DESCRIPTION

MEL-ROL waterproofing system is a flexible, versatile, dependable, roll-type waterproofing membrane. It is composed of a nominally 56 mil thick layer of polymeric waterproofing membrane on a heavy duty, four-mil thick, cross-laminated polyethylene carrier film. The two components are laminated together under strict quality-controlled production procedures.

A handy overlap guideline is printed 63.5 mm (2 1/2") in from the material edge on each side to assure proper overlap coverage and assist in maintaining a straight application. Special exposed polymeric membrane strips are provided on both sides for positive membrane-to-membrane adhesion in the overlap area. The membrane strips are protected by a pull-off release strip. All components of the MEL-ROL waterproofing system work together to provide a cost-effective, positive waterproofing system that's quick and easy to apply.

W. R. MEADOWS accessory products included in the MEL-ROL waterproofing system are: BEM, MEL-ROL LIQUID MEMBRANE, MEL-PRIME adhesive (solvent-based and water-based), POINTING MASTIC, DETAIL STRIP, CATALYTIC BONDING ASPHALT, TERMINATION BAR, PROTECTION COURSE, and MEL-DRAIN™ drainage board.

USES

MEL-ROL waterproofing system provides a cost-effective answer to properly waterproof foundations, vertical walls, and below-grade floors in residential and commercial construction. It is equally effective for use as between-the-slab waterproofing on plaza decks, parking decks and structural slabs. Use it as a waterproofing membrane to isolate mechanical and electronic rooms, laboratories, kitchens, and bathrooms. MEL-ROL offers positive protection when "wrapped around" major rapid transit, vehicular, utility, and pedestrian tunnel projects. MEL-ROL can also be used on insulated concrete forms (ICF).

Installation of PROTECTION COURSE, from W. R. MEADOWS is recommended before backfilling. MEL-ROL can also be used with drainage boards when specified.

FEATURES/BENEFITS

- Provides a cost-effective, flexible, versatile, dependable, positive waterproofing protection against damaging moisture migration and the infiltration of free water.
- Offers a quick and easy-to-apply system for maximum productivity.
- Special membrane-to-membrane adhesion provides additional overlap security.
- Meets or exceeds the test requirements of all currently applicable specifications.
- Components work together for positive waterproofing protection.
- Handles with ease on the jobsite.
- Available in a low temperature version for use when air and surface temperatures are between -7° C (20° F) and 16° C (60° F). An extra-low temp version is also available, ideal for application in extra-low temperatures down to -18° C (0° F).

PACKAGING

977.69 mm (38.5") wide x 19.1 m (62.5') long, one roll per carton.

COVERAGE

Provides 18.6 m² (200 ft.²) per roll. Gross coverage is 18.6 m² (200 ft.²). [Net coverage is 17.4 m² (187.5 ft.²) with overlap of 63.5 mm (2 1/2").]

STORAGE AND HANDLING

Store membrane cartons on pallets and cover if left outside. Keep materials away from sparks and flames. Store membrane where temperature will not exceed 32° C (90° F) for extended periods of time.

SPECIFICATIONS

A.R.E.M.A.® Specifications Chapter 29, Waterproofing

W. R. MEADOWS OF CANADA
70 Hannant Court, Milton, ON L9T 5C1
Phone: (905) 878-4122 • Fax: (905) 878-4125
Montreal Sales: (877) 405-5186

Hampshire, IL / Cartersville, GA / York, PA / Fort Worth, TX
Benicia, CA / Pomona, CA / Goodyear, AZ / Milton, ON
St. Albert, AB
www.wrmeadows.com

MEL-ROL COMBINES POSITIVE WATERPROOFING PROTECTION WITH EASE OF HANDLING

EXCLUSIVE FEATURES

A handy overlap guideline is printed 63.5 mm (2 1/2") in from the material edge on each side, assuring proper overlap coverage and assisting in maintaining a straight application. The polymeric waterproofing membrane is protected by a special, easy-to-remove release paper. The exposed membrane strips on the material edges are protected by a pull-off release strip. Exposed polymeric membrane strips are provided on both sides of MEL-ROL for positive membrane-to-membrane adhesion in the overlap area . . . note the detail, as shown in inset photo.

TECHNICAL DATA			
PROPERTY	TYPICAL VALUE		TEST METHOD
COLOUR	Carrier Film	White	
	Polymeric Membrane	Black	
THICKNESS	Carrier Film	4 mils	
	Polymeric Membrane	56 mils	
TENSILE STRENGTH	Carrier Film	40.71 MPa (5900 psi) min.	ASTM D 412 (Die C)
	Membrane	3230 KPa (460 psi) min.	
ELONGATION	971.3%		ASTM D 412
LOW TEMP CRACK BRIDGING	100 Cycle -32° C (-25° F)	Pass	ASTM C 836
PEEL ADHESION	2068 N/m (11.8 lb./in.)		ASTM D 903
LAP ADHESION	1508.5 N/m (8.62 lbf/in.)		ASTM D 1876
WATER VAPOUR PERMEABILITY	0.036 Perms		ASTM E-96, B
WATER ABSORPTION	0.1%, 72 hrs. max.		ASTM D 1970
HYDROSTATIC RESISTANCE	Equiv. to 70.38 m (230.9') of water		ASTM D 5385
PUNCTURE RESISTANCE	214.6 N (48.24 lbf)		ASTM E 154
EXPOSURE TO FUNGI	Pass, 16 weeks		Soil Test
FLEXIBILITY @ -29° C (-20° F)	Pass		ASTM D 1970

MEL-ROL IS QUICK AND EASY TO APPLY

APPLICATION

Surface Preparation ... Concrete should be cured at least 72 hours, be clean, dry, smooth, and free of voids. Repair spalled areas; fill all voids and remove all sharp protrusions.

Temperature ... Apply in dry, fair weather when the air and surface temperatures are above 4° C (40° F). Do not apply to frozen concrete.

MEL-ROL LOW TEMP can be used when air and surface temperatures are between -7° C (20° F) and 16° C (60° F).

Surface Conditioning ... Apply MEL-PRIME adhesive to surfaces that will be covered in one working day. If left exposed overnight, additional adhesive must be applied. Follow all instructions and precautions shown on primer containers.

REMOVE release paper from MEL-ROL from the top edge of the roll and firmly press exposed area to the wall. Remove the release paper from the rolls in a downward direction, pressing MEL-ROL into place on the wall.

Footing Details ... Use DETAIL STRIP for impaction sheet coverage. First, fold strips lengthwise and then cut at the fold. Material is then ready to install as 114.3 mm (4 1/2") strips on either side of the rebar. Any excess can be turned down on the face of the footing. Next, fill the voids around rebars in the keyway with CATALYTIC BONDING ASPHALT. Pour the walls. Install DETAIL STRIP horizontally along the wall where it meets the footing, placing half the material up the wall and the other half onto the footing. Extend the material 114.3 mm (4 1/2") beyond outside corners. Slit extended portion of DETAIL STRIP lengthwise. Place the horizontal flap out onto the footing and bend the vertical flap around the wall. See *Diagram A*. Repeat this procedure in the opposite direction as shown in *Diagram B*.

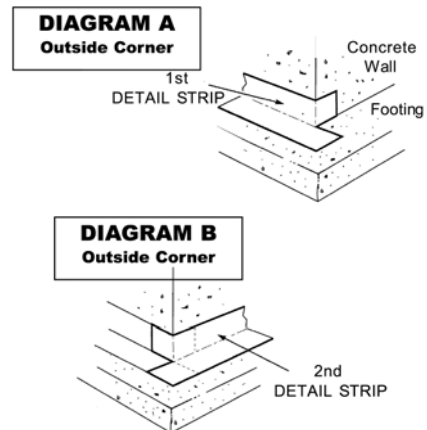

MEL-ROL can be applied to concrete, masonry surfaces, wood, insulated wall systems, and metal. All substrates must be clean, dry, and free of all surface irregularities.

Horizontal Application ... Remove release paper on edge, then position the MEL-ROL membrane. Pull balance of release paper off, running the roll from low to high points, so all laps will shed water. Stagger end laps and overlap all seams at least 63.5 mm (2 1/2"). Apply a double thickness of the MEL-ROL membrane over construction, control, all expansion joints and over cracks greater than 1.59 mm (1/16") wide.

Vertical Wall Application ... Masonry walls may require the application of a cementitious parge-coat. Allow the parge-coat to dry before priming and applying MEL-ROL. When applied, the parge-coat will produce a smooth, uniform, and well-bonded surface. Remove release paper, then apply vertically in lengths approximately 2.4 m (8') long over the top of the horizontal DETAIL STRIP at the footing. Overlap seams at least 63.5 mm (2 1/2"). Tightly butt edges of membrane and apply POINTING MASTIC in corner applications. (See *Diagram C.*)

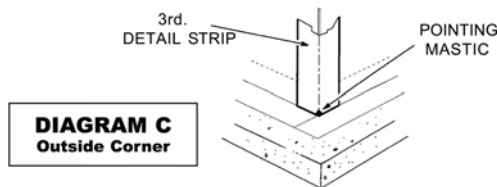

Outside Corners ... Bend DETAIL STRIP vertically over the outside corner and extend 114.3 mm (4 1/2") beyond each side of the corner. Terminate the material at the footing. Finish the corner with POINTING MASTIC. (See *Diagram C.*)

Drains and Protrusions ... All protrusions should be sealed with two layers of membrane applied at least 152 mm (6") in all directions. Seal all terminations with POINTING MASTIC. Around drains, apply two layers of MEL-ROL and put a bead of POINTING MASTIC between the membrane and clamping rings and at all terminations, drains, and protrusions. See ASTM D 5898.

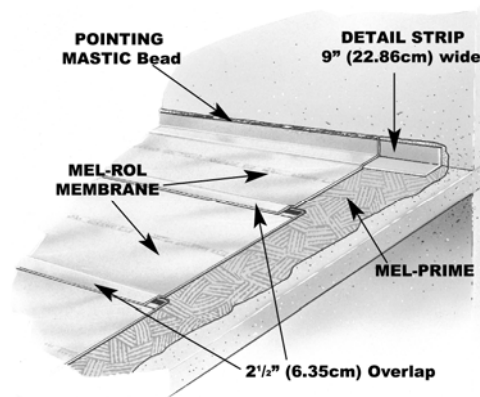

To the top terminations, apply POINTING MASTIC at least 3.18 mm (1/8") thick and 25.4 mm (1") wide. As an option, TERMINATION BAR may be used to mechanically fasten the membrane.

Hand-Rub and Roll Press ... Once positioned, immediately hand-rub MEL-ROL membrane firmly to the surface, removing any bubbles or wrinkles, then pressure roll the complete surface to assure positive adhesion.

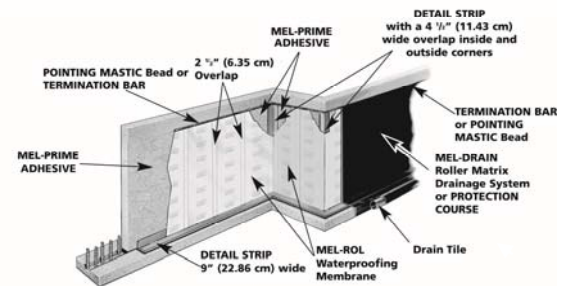

Inside Corners ... Before MEL-ROL is applied, place a vertical DETAIL STRIP on inside corners extending the material 114.3 mm (4 1/2") beyond each side of the corner. (See *Diagram D.*) Terminate at the footing and finish the corner with POINTING MASTIC.

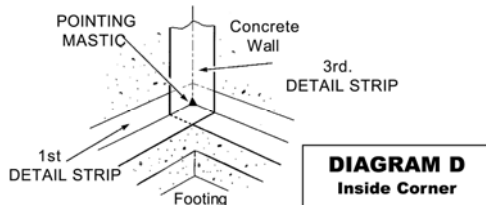

Inspect and Repair ... A thorough inspection should be made before covering and all necessary repairs made immediately. Tears and inadequate overlaps should be covered with MEL-ROL ... slit fish mouths and patch. Seal edges of all patches with POINTING MASTIC. Where applicable, horizontal applications can be flood-tested for 24 hours. All leaks should be marked and repaired when membrane dries.

® is a registered trade mark of W. R. Meadows

WARRANTY: W. R. Meadows of Canada warrants that, at the time and place we make shipment, our materials will be of good quality and will conform with our published specifications in force on the date of acceptance of the order. THE FOREGOING WARRANTY SHALL BE EXCLUSIVE AND IN LIEU OF ANY OTHER WARRANTY, EXPRESS OR IMPLIED, INCLUDING THE IMPLIED WARRANTIES OF MERCHANTABILITY AND FITNESS FOR A PARTICULAR PURPOSE AND ALL OTHER WARRANTIES OTHERWISE ARISING BY OPERATION OF LAW, COURSE OF DEALING, CUSTOM OF TRADE OR OTHERWISE. As the exclusive remedy for breach of this Warranty, we will replace defective materials, provided, however, that the buyer examine the materials when received and promptly notify us in writing of any defect before the materials are used or incorporated into a structure. Three (3) months after W. R. Meadows of Canada has shipped the materials, all our Warranty and other duties with respect to the quality of the materials delivered shall conclusively be presumed to have been satisfied, all liability therefore terminates and no action for breach of any such duties may thereafter be commenced. W. R. Meadows of Canada shall in no event be liable for consequential damages. Unless otherwise agreed to in writing, no warranty is made with respect to materials not manufactured by W. R. Meadows of Canada. We cannot warrant or in any way guarantee any particular method of use or application or the performance of materials under any particular condition. Neither this Warranty nor our liability may be extended or amended by our salesmen, distributors or representatives, or by our distributor's representatives, or by any sales information or drawings.

Protect the Membrane ... on all vertical and horizontal installations with the immediate application of PROTECTION COURSE if no drainage system is used, or MEL-DRAIN. To secure PROTECTION COURSE, use POINTING MASTIC as an adhesive, and/or physically attach at the top edge using TERMINATION BAR. Backfilling should be done immediately, using care and caution to avoid damaging the waterproofing application.

PRECAUTIONS

Avoid the use of products that contain tars, solvents, pitches, polysulfide polymers, or PVC materials that may come into contact with MEL-ROL. The use of MEL-ROL does not negate the need for relief of hydrostatic heads. A complete drain tile system should be placed around the exterior of footing and under slabs, as required.

ACCESSORIES

MEL-PRIME W/B ... This water-based adhesive prepares concrete surfaces for MEL-ROL application. Arrives ready to use. Requires no additional mixing. MEL-PRIME W/B emits no unpleasant odours and works with all W. R. MEADOWS waterproofing membranes. Applies easily with manual sprayer or roller; VOC compliant. MEL-PRIME W/B is for use at temperatures of 4° C (40° F) and up.

COVERAGE: 6.14 to 8.59 m²/L (250 to 350 ft.²/U.S. gal.)

PACKAGING: 3.78 L (1 U.S. gal) Units (4 units per carton); 18.93 L (5 U.S. gal) Pails

MEL-PRIME ... This solvent-based adhesive is for use at temperatures of -4° C (25° F) and above. Apply by roller.

COVERAGE: 6.14 to 8.59 m²/L (250 - 350 ft.²/U.S. gal.)

PACKAGING: 18.93 L (5 U.S. Gal) Pails

MEL-ROL LIQUID MEMBRANE ... A two-component material used as a flashing to form fillets at corners and at protrusions. May be used as a substitute for POINTING MASTIC. Product can also be used in between walls and footings in lieu of DETAIL STRIP.

COVERAGE: As a fillet, approximately 10.87 meters per litre (135 LF per U.S. gal).

PACKAGING: 3.78 L (1 U.S. gal) Units, 4 units per carton.

BEM ... BEM can be used as a fillet to round out 90° angles, such as the wall-footing connection, and can be used as a substitute for MEL-ROL LIQUID MEMBRANE.

COVERAGE: As a fillet, approximately 10.9 m/L (135 lineal ft./gal.)

PACKAGING: 828 mL (28 oz.) cartridges (12/carton)

POINTING MASTIC ... Used as an adhesive and for sealing top edge terminations on DETAIL STRIP and membrane, and to adhere PROTECTION COURSE.

COVERAGE: 3.18 mm x 25.4 mm x 16.10 ml (1/8" x 1" x 200/U.S. gal)

PACKAGING: 18.93 L (5 U.S. gal) Pails, 857.65 ml (29 fluid ounce) cartridges, 12/carton.

CATALYTIC BONDING ASPHALT ... Easy-to-apply, one-component material for sealing around rebar.

COVERAGE: 4.9 m²/L (1000 ft.²/U.S. gal)

PACKAGING: 18.93 L (5 U.S. Gallon) pails

DETAIL STRIP ... Convenient, easy-to-use DETAIL STRIP provides an economical and effective method for sealing vertical and horizontal butt joints, i.e. inside or outside corners and where walls and footings meet.

PACKAGING: .23 m x 15.24 m (9' x 50') roll, 4 rolls per carton.

PROTECTION COURSE ... Use for vertical and horizontal applications. Adhere with POINTING MASTIC or use mechanical fasteners.

PACKAGING: 1.22 x 2.44 m (4' x 8') panels

MEL-DRAIN ... is a dimple-raised moulded polystyrene fabric designed to provide high flow capacity to reduce hydrostatic pressure build-up around waterproofing and vapourproofing membranes. Choice of drain types are available for vertical, horizontal, and site applications. Use MEL-PRIME to condition surface prior to application of MEL-DRAIN.

TERMINATION BAR ... is a high strength, pre-formed, multi-purpose, plastic strip designed to support vertical membrane systems and PROTECTION COURSE at their termination point.

PACKAGING: 3.04 m (10') [holes every 150 mm (6") o/c, 50.8 mm (2") from either end], 25 pieces per carton.

MAINTAIN ENERGY EFFICIENCY

Wet insulating materials lose much of their "R" factor performance characteristics, reducing the energy efficiency of the structure. W. R. MEADOWS thermal and moisture protection products play a key role in *maintaining* the structure's energy efficiency and aiding in the integrity of other structural systems, such as insulation.

MASTERFORMAT NUMBER AND TITLE

07 13 26 – Self-Adhering Sheet Waterproofing

LEED INFORMATION

May help contribute to LEED credits:

- EA Credit 1: Optimize Energy Performance
- IEQ Credit 3.1: Construction Indoor Air Quality Management Plan: During Construction
- IEQ Credit 7.1: Thermal Comfort - Design
- MR Credit 2: Construction Waste Management
- MR Credit 5: Regional Materials

For CAD details, most recent data sheet, further LEED information, and MSDS, visit www.wrmeadows.com.